

Description

GM3326 is step-up/down DC/DC converter controller ICs with fast, and low ON resistance drivers built-in. A versatile step-up/ down DC/DC converter can be realised by using with large output current only 4 basic external components - transistors, coils, diodes, and capacitors.

Output voltage is selectable in 0.1V steps within a 2.4V ~ 6.0V (± 2.5% accuracy) range, and switching frequency is set at or 300KHz.

GM3326 switches from PWM to PFM control during light loads, and the series offers high efficiencies from light loads through to large output currents.

Soft-start time is internally set to 10 msec, which offers protection against rush currents when the power is switched on and also against voltage overshoot.

During shutdown (CE pin = L), consumption current can be reduced to as little as 0.5µA or less.

Features

- ◆ **Input Voltage Range** : 2.0V ~ 10V
- ◆ **Output Voltage Range** : 2.4V ~ 6.0V (± 2.5% accuracy) (selectable in 0.1V steps)
- ◆ **Oscillation Frequency** : 300KHz (± 15% accuracy)
- ◆ **Output Current** : more than 250mA ($V_{IN}=2.4V$, $V_{OUT}=3.3V$)
- ◆ **Efficiency** : 81% (typ) at 5.0V, 78% (typ) at 3.3V
- ◆ **Stand-By** : ISTB = 0.5µA (max)
- ◆ **Output Voltage Internal Set-Up**
- ◆ **SOT-25 Package**

Application

Mobile phones

PDA's

Palmtop computers

Portable audio equipment

Various power supplies

TYPICAL APPLICATION CIRCUITS

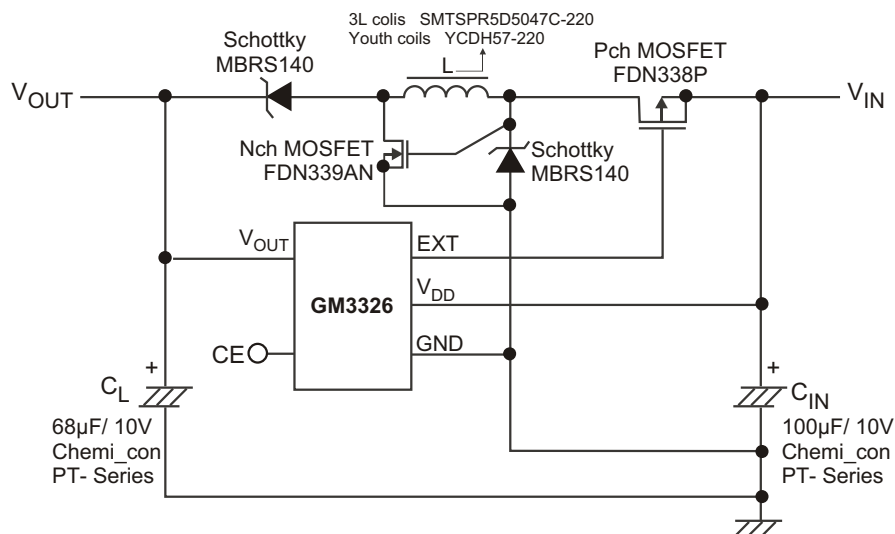

◆ MARKING INFORMATION & PIN CONFIGURATIONS

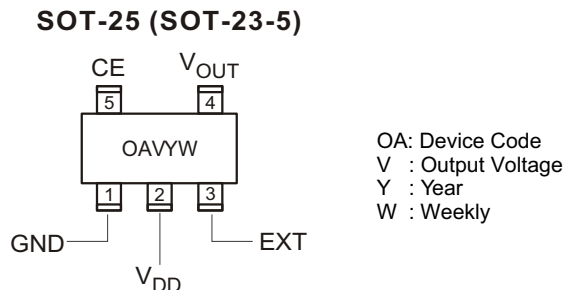

◆ ORDERING INFORMATION

Ordering Number	Output Voltage	Suffix	Package	Shipping
GM3326-2.5ST25R	2.5	B	SOT-25	3,000 Units/ Tape & Reel
GM3326-2.8ST25R	2.8	E	SOT-25	3,000 Units/ Tape & Reel
GM3326-3.0ST25R	3.0	G	SOT-25	3,000 Units/ Tape & Reel
GM3326-3.3ST25R	3.3	J	SOT-25	3,000 Units/ Tape & Reel
GM3326-3.5ST25R	3.5	L	SOT-25	3,000 Units/ Tape & Reel
GM3326-4.0ST25R	4.0	Q	SOT-25	3,000 Units/ Tape & Reel
GM3326-4.5ST25R	4.5	V	SOT-25	3,000 Units/ Tape & Reel
GM3326-5.0ST25R	5.0	A	SOT-25	3,000 Units/ Tape & Reel
GM3326-5.5ST25R	5.5	F	SOT-25	3,000 Units/ Tape & Reel
GM3326-6.0ST25R	6.0	K	SOT-25	3,000 Units/ Tape & Reel

* For detail Ordering Number identification, please see last page.

◆ ABSOLUTE MAXIMUM RATINGS

PARAMETER	SYMBOL	RATINGS	UNITS
V_{DD} Pin Voltage	V_{DD}	-0.3 ~ 12	V
V_{OUT} Pin Voltage	V_{OUT}	-0.3 ~ 12	V
CE Pin Voltage	V_{CE}	-0.3 ~ 12	V
EXT/ Pin Voltage	$V_{EXT/}$	-0.3 ~ V_{DD} +0.3	V
EXT/ Pin Current	$I_{EXT/}$	± 100	mA
Power Dissipation	P_d	150	mW
Operating Ambient Temp.	T_{opr}	-40 ~ +85	°C
Storage Temp.	T_{stg}	-40 ~ +125	°C

◆ BLOCK DIAGRAM

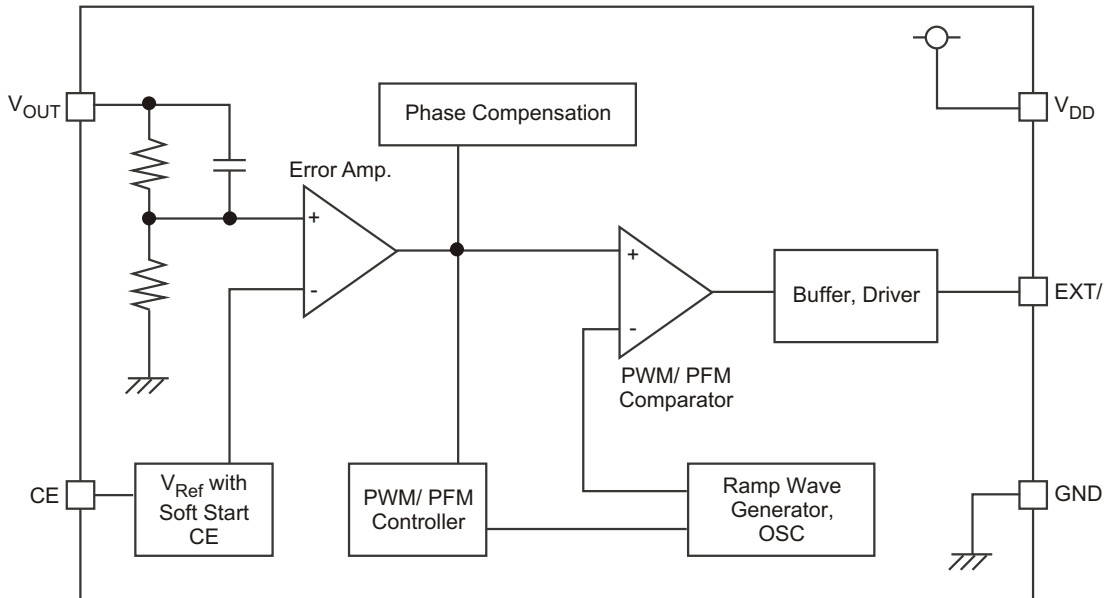

Block Diagram Explanation

<Error Amp.>

The error amplifier is used as an output voltage monitor. It compares the reference voltage with the feedback from the voltage divided by the internal resistor. Should a voltage higher than the reference voltage be feedback, the output of the error amp will increase.

<PWM Comparator>

The PWM comparator compares the output of the error amp with the ramp wave. When the voltage at the output of the error amp is low, the EXT/ pin will be LOW level (Switching ON time).

<Ramp Wave Generator>

The ramp wave generator, as the name suggests, generates the switching frequency's ramp wave.

<PWM / PFM Controller>

With the GM3326 series, control is automatically switched between PWM and PFM according to the size of the load.

<Vref with Soft Start, CE>

The start up of the Vref voltage at the error amp's input is gradual due to the internal capacitor and low current circuit. Because of this soft-start function, the operations of the error amp's 2 inputs are balanced and the EXT/ pin's ON time can be manipulated to produce longer ON times.

Further, with the UVLO function, the signal will be such so as not to turn the MOS switch ON until any instability in the internal circuit stabilizes during soft-start time. Even in cases where input voltage is so low as to produce instability in the IC, the UVLO function will operate and the MOS switch will be turned OFF.

[Step-up&down DC/DC Converter]

Set output voltage obtained as a result of the automatic switching operations of the IC regardless of the difference between input voltage and set output voltage.

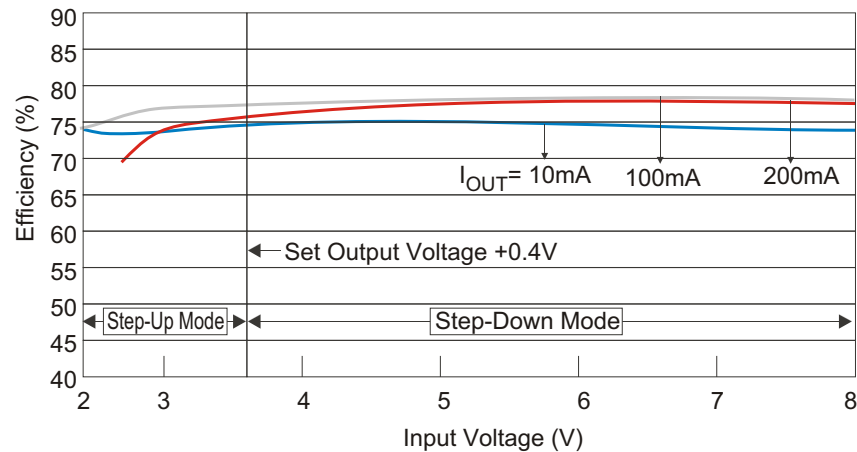

Figure 1. Input Voltage vs. Efficiency

The above graph shows that over a wide input voltage range, the efficiency of the GM3326 is more or less constant. In applications that use either a standard dry 3 cell battery or a cell lithium Ion battery to obtain an output of 3.3V, for example, the efficiency of GM3326 is again much better. Due to GM3326 does not have a series regulator output, we recommend a test with samples for use in applications where ripple voltage is a problem.

External Components Selection (Notes)

The performance of the DC/DC converter IC circuit is heavily reliant upon the performance of the surrounding circuitry and components. In particular, since the V_F voltage of the Schottky Diode used will have a direct effect upon efficiency, the smaller the diode, the better the efficiency obtainable. (Refer to the graph below)

It is also recommended that a switching MOSFET with a small ON resistance be used. With GM3326, an ON resistance of 500m or less is recommended.

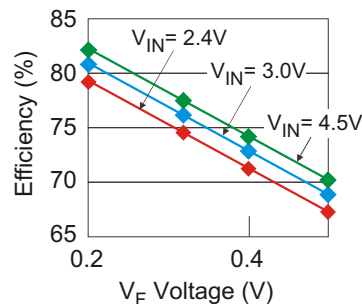
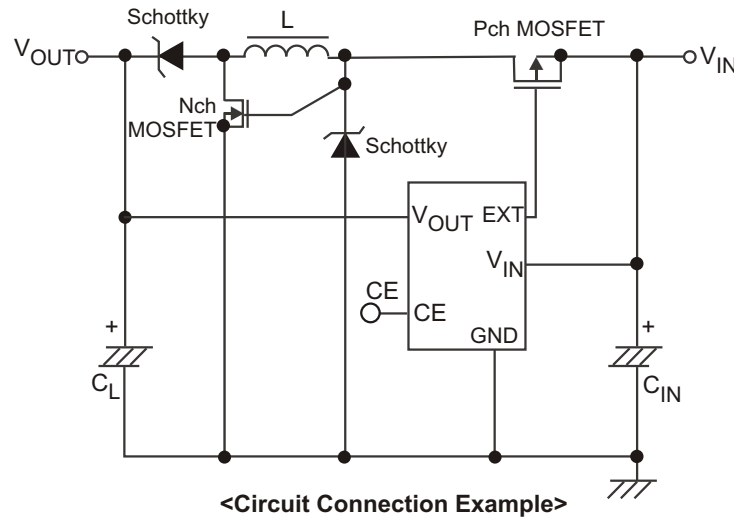

Figure 2. $V_{OUT}= 3.3V$, $I_{OUT}= 100mA$

◆ OPERATIONAL EXPLANATION



GM3326 is PWM (PWM/ PFM switching) step-up/down DC/DC converter controller ICs. GM3326 switches to PFM operations during light loads and is very efficient over a wide range in relation to load. Further, the efficiency can be maintained over a wide input voltage range as both step-up & step-down operations are PWM controlled. Output voltage settings are laser trimmed.

[ON TIME]

P-Ch MOSFET = ON, N-Ch MOSFET = ON : Current flows from V_{IN} via Pch MOSEFT, L, Nch FET to GND : L is charged.

[OFF TIME]

P-Ch MOSFET (PSW) = OFF, N-Ch MOSFET (NSW) = OFF : Current flows from GND via Schottky 1, L, Schottky 2, to V_{OUT} : V_{OUT} rises due to the charge stored at L. By comparing V_{OUT} with the internal reference voltage, the ON TIME vs OFF TIME ratio can be regulated & output stability can be protected.

◆ ELECTRICAL CHARACTERISTICS (GM3326- 3.3V)

$V_{OUT}= 3.3V, F_{OSC}= 300kHz$

$T_A= 25^{\circ}C$

PARAMETER	SYMBOL	CONDITIONS	Min	Typ	Max	Unit
Output Voltage	V_{OUT}		3.218	3.300	3.383	V
Supply Voltage	V_{DD}		2.0	-	10.0	V
Supply Current 1	I_{DD1}	$V_{OUT}= CE$: Set Output Voltage X 0.95 applied	-	130	200	μA
Supply Current 2	I_{DD2}	$V_{OUT}= CE$: Set Output Voltage + 0.5 applied	-	20	35	μA
Stand- By Current	I_{STB}	$V_{OUT}=$ Set Output Voltage X 0.95 applied, CE= 0V	-	-	0.5	μA
Oscillation Frequency	F_{OSC}	$V_{DD}=V_{OUT}= CE$: Set Output Voltage X 0.95 applied	255	300	345	KHz
Max. Duty Ratio	MAXDTY	$V_{DD}=V_{OUT}= CE$: Set Output Voltage X 0.95 applied	78	85	92	%
PFM Duty Ratio	PFMDTY	No load	15	25	35	%
Efficiency ^{Note 1}	EFFI	$V_{DD}=V_{IN}= CE$: Set Output Voltage X 0.95 applied	-	78	-	%
Soft- Start Time	T_{SS}		5.0	10.0	20.0	mS
CE 'H' Voltage	V_{CEH}	V_{OUT} : Set Output Voltage X 0.95 applied	0.65	-	-	V
CE 'L' Voltage	V_{CEL}	V_{OUT} : Set Output Voltage X 0.95 applied	-	-	0.20	V
EXT/ 'H' ON Resistance	R_{EXTBH}	Same as I_{DD1} , $V_{EXT}/ = V_{OUT} - 0.4V$	-	29	43	
EXT/ 'L' ON Resistance	R_{EXTBL}	Same as I_{DD1} , $V_{EXT}/ = 0.4V$	-	19	27	

Measuring Condition: Unless otherwise stated, $V_{DD}= 3.3V, I_{OUT}= 130mA$

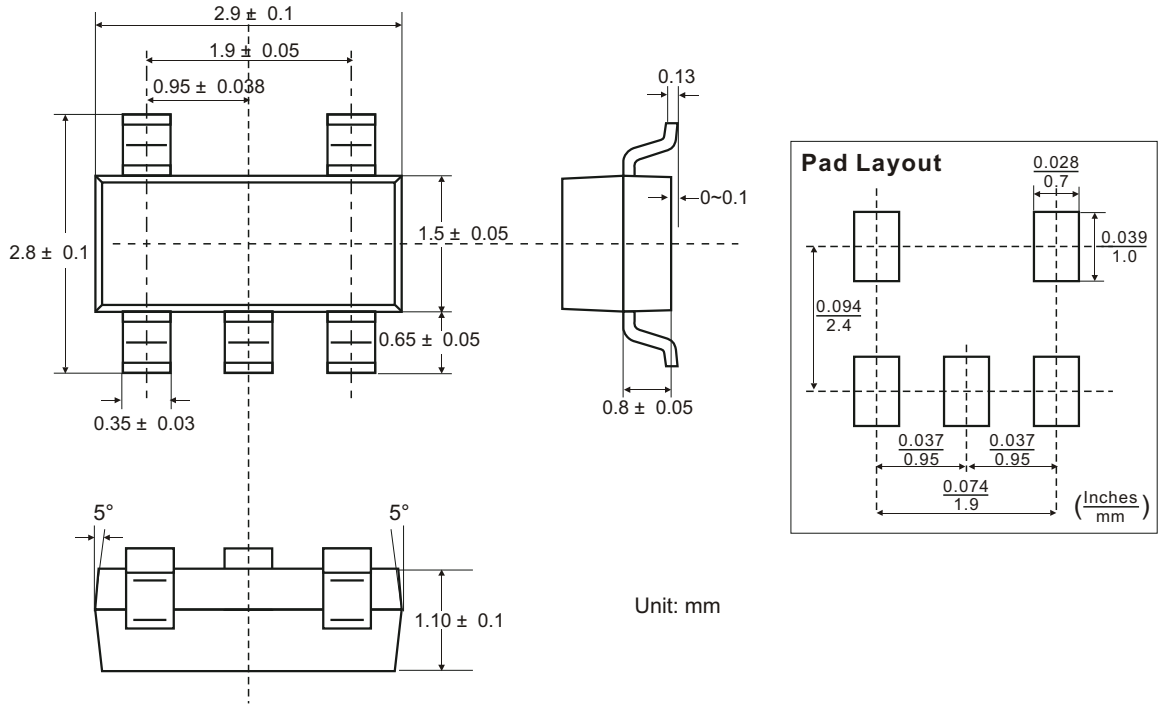

Note 1: $EFFI = \frac{[(Output\ Voltage) \times (Output\ Current)]}{[(Input\ Voltage) \times (Input\ Current)]} \times 100$

◆ SOT-25(SOT-23-5) PACKAGE OUTLINE DIMENSIONS

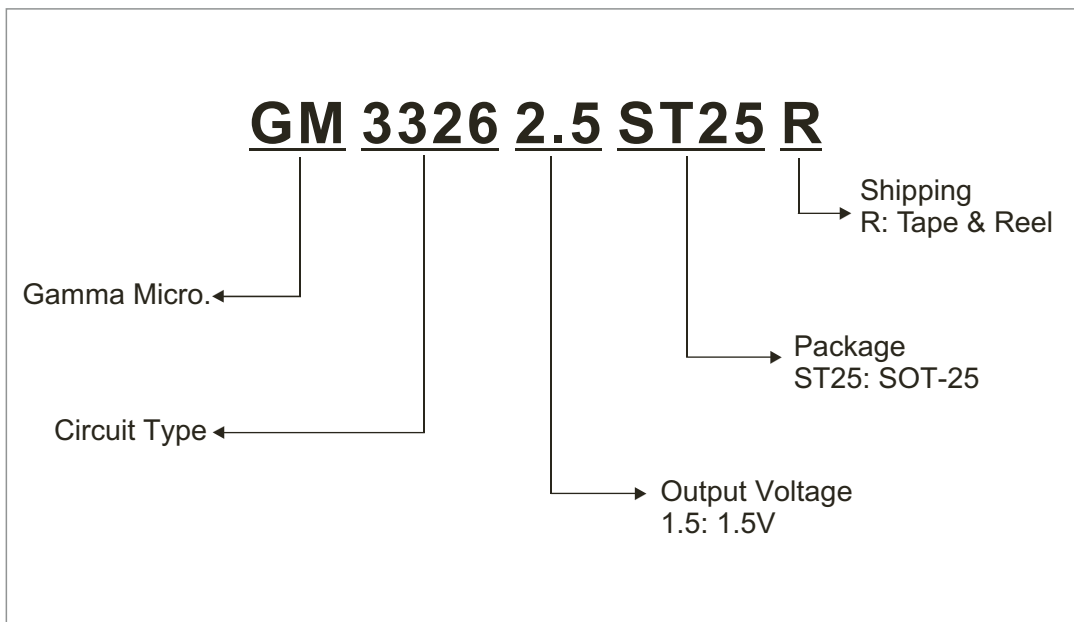

◆ ORDERING NUMBER



GAMMA Micro, , and  are registered trademarks of GAMMA MICROELECTRONICS INC. GAMMA reserves the right to make changes without further notice to any products herein. Information provided herein is alleged to be exact and consistent and this publication surpasses and replaces all information previously supplied.

GAMMA makes no warranty the suitability of its products for any particular purpose, nor does GAMMA assume any liability arising out of the application or use of any product or circuit, and specifically disclaims any and all liability including without limitation special, consequential or incidental damages.

GAMMA products are not authorized for using as critical components in life support devices or systems without prior written approval from GAMMA MICROELECTRONICS INC.
