

## Description

GM38C4x is fixed frequency, high performance, and current-mode PWM controllers. Gamma's BiCMOS devices are pin compatible with standard 384x bipolar devices but with several improvements.

Undervoltage lockout circuitry allows the '42 and '44 versions to start up at 14.5V and operate down to 9V, and the '43 and '45 versions start at 8.4V with operation down to 7.6V. All versions operate up to 16V.

When compared to bipolar 384x devices operating from a 15V supply, start-up current has been reduced to 50 $\mu$ A typical and operating current has been reduced to 4.0 mA typical. Decreased output rise/fall times drive larger MOSFETs, and rail-to-rail output capability increases efficiency, especially at lower supply voltages. GM38C4x also features a trimmed oscillator discharge current and bandgap reference.

GM38C4x denotes 8-pin plastic DIP and SOP packages.

## Features

- ◆ 40ns output rise and 30ns output fall times
- ◆ -40° to +85°C temp. range same as standard UC284x
- ◆ Low-power BiCMOS Process
- ◆ Very low start-up current (50 $\mu$ A typical)
- ◆ Low operating current (4mA typical)
- ◆ CMOS outputs with rail-to-rail swing
- ◆  $\geq$ 500kHz current-mode operation
- ◆ Pin-for-pin compatible with UC3842/ 3843 / 3844/ 3845(A)
- ◆ Trimmed oscillator discharge current
- ◆ UVLO with hysteresis
- ◆ Low cross-conduction currents

## Application

Current-mode, off-line, switched-mode power supplies  
Current-mode, dc-to-dc converters.  
Step-down "buck" regulators

Step-up "boost" regulators  
Flyback, isolated regulators  
Forward converters  
Synchronous FET converters

#### ◆ MARKING INFORMATION & PIN CONFIGURATIONS (TOP VIEW)

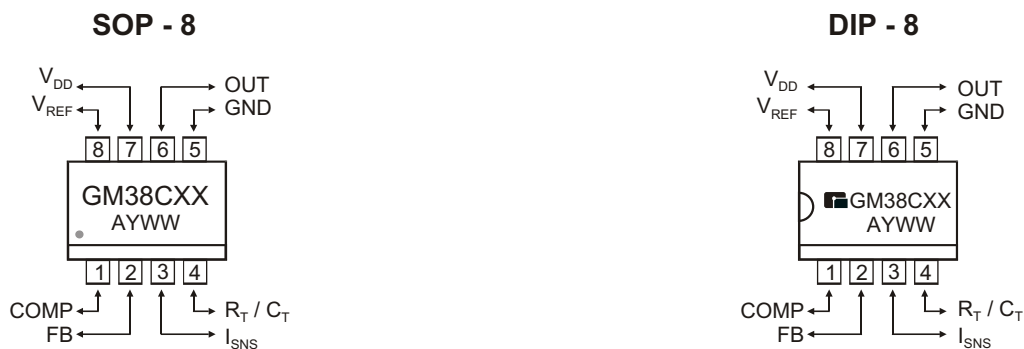

A = Assembly Location  
 Y = Year  
 W W = Weekly

#### ◆ ORDERING INFORMATION

Ordering Number	Package	Shipping
GM38C42S8T	SOP - 8	100 Units/ Tube
GM38C42S8R	SOP - 8	2,500 Units/ Tape & Reel
GM38C42D8T	DIP-8	60 Units/ Tube
GM38C43S8T	SOP - 8	100 Units/ Tube
GM38C43S8R	SOP - 8	2,500 Units/ Tape & Reel
GM38C43D8T	DIP-8	60 Units/ Tube
GM38C44S8T	SOP - 8	100 Units/ Tube
GM38C44S8R	SOP - 8	2,500 Units/ Tape & Reel
GM38C44D8T	DIP-8	60 Units/ Tube
GM38C45S8T	SOP - 8	100 Units/ Tube
GM38C45S8R	SOP - 8	2,500 Units/ Tape & Reel
GM38C45D8T	DIP-8	60 Units/ Tube

\* For detail Ordering Number identification, please see last page.

#### ◆ ABSOLUTE MAXIMUM RATINGS

PARAMETER	SYMBOL	VALUE	UNIT
Zener Current Operation at $\geq 16V$ may require special precautions(Note6)	$I_{DD}$	30	mA
Supply Voltage(Note 6)	$V_{DD}$	18	V
Switch Supply Voltage	$V_D$	18	V
Current Sense Voltage	$V_{ISNS}$	- 0.3 to + 5.5	V
Feedback Voltage	$V_{FB}$	- 0.3 to + 5.5	V
Output Current	$I_{OUT}$	0.5	A
Storage Temperature	$T_A$	- 50 to + 150	$^{\circ}C$

#### ◆ OPERATING RATINGS

PARAMETER	SYMBOL	VALUE	UNIT
Junction Temperature	$T_J$	150	$^{\circ}C$

#### ◆ PACKAGE PIN DESCRIPTION

PIN LEAD	FUNCTION	FUNCTION
1	COMP	Compensation: Connect external Compensation network to modify the error amplifier output.
2	FB	Feedback (Input): Error amplifier input .Feedback is 2.5Vat desired output voltage.
3	$I_{SNS}$	Current Sense (Input): Current sense comparator input. Connect to current sensing resistor or current transformer.
4	$R_T / C_T$	Timing Resistor / Timing Capacitor: Connect external RC network to select switching frequency.
5	GND	Ground: Combined analog and power ground.
6	OUT	Power Output: Totem - pole output.
7	$V_{DD}$	Analog Supply (Input): Controller circuitry supply input. Return to analog ground (AGND).
8	$V_{REF}$	5V Reference (Output): Connect external RC network.

#### ◆ BLOCK DIAGRAM

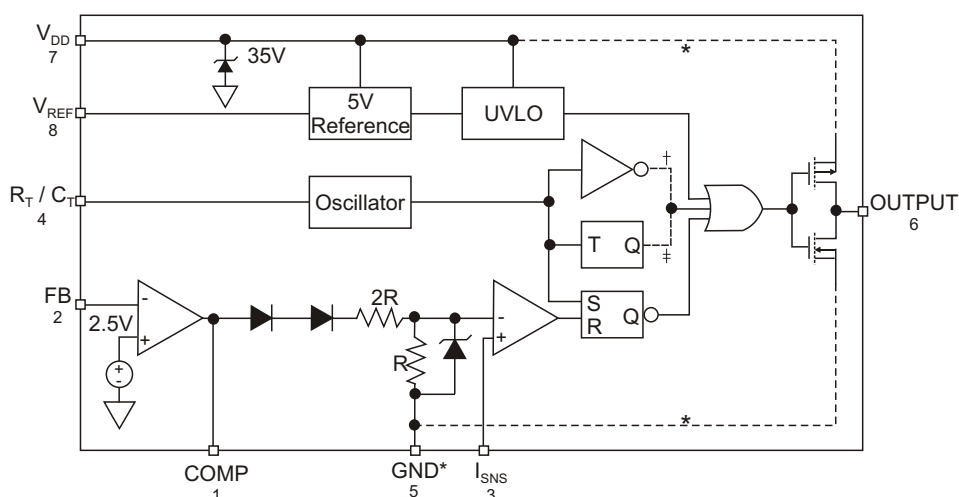

\* 8 - lead versions only

#### ◆ ELECTRICAL CHARACTERISTICS

( $T_A = -40^{\circ}\text{C}$  to  $85^{\circ}\text{C}$ , Note 4,  $V_{DD} = 15\text{V}$ ,  $C_T = 3.3\text{ nF}$ ,  $R_T = 10\text{ k}\Omega$ , unless otherwise noted )

CHARACTERISTICS	TEST CONDITIONS	MIN	TYP	MAX	UNIT
<b>Reference Section</b>					
Output Voltage	$T_A = 25^{\circ}\text{C}$ , $I_O = 1\text{ mA}$	4.9	5.0	5.1	V
Line Regulation	$12\text{V} \leq V_{DD} \leq 16\text{V}$ , $I_O = 5\mu\text{A}$ , (Note 6)		2	20	mV
Load Regulation	$1 \leq I_O \leq 20\text{ mA}$		1	25	mV
Temp. Stability	(Note 1)		0.2		mV / $^{\circ}\text{C}$
Total Output Variation	Line, Load, Temp., Note 1	4.82		5.18	V
Output Noise Voltage	$10\text{ Hz} \leq f \leq 10\text{ kHz}$ , $T_A = 25^{\circ}\text{C}$ , (Note 1)		50		$\mu\text{V}$
Long Term Stability	$T_A = 125^{\circ}\text{C}$ , 1000hrs., (Note 1)		5	25	mV
Output Short Circuit		-30	-80	-180	mA
<b>Oscillator Section</b>					
Initial Accuracy	$T_A = 25^{\circ}\text{C}$ , (Note 5)	49	52	55	KHz
Voltage Stability	$12 \leq V_{DD} \leq 16\text{V}$ , (Note 6)		0.2	1.0	%
Temp. Stability	$T_{\text{MIN}} \leq T_A \leq T_{\text{MAX}}$ , (Note 1)		0.04		% / $^{\circ}\text{C}$
Clock Ramp Reset Current	$T_A = 25^{\circ}\text{C}$ , $V_{\text{RT/CT}} = 2\text{V}$ , $T_{\text{MIN}} \leq T_A \leq T_{\text{MAX}}$	7.7 7.2	8.4 8.4	9.0 9.5	mA
Amplitude	$V_{\text{RT/CT}}$ (Peak to Peak)		1.9		Vp-p
<b>Error Amplifier Section</b>					
Input Current	$V_{\text{FB}} = 5\text{V}$		-0.1	-2	$\mu\text{A}$
Input Voltage	$V_{\text{COMP}} = 2.5\text{V}$	2.42	2.5	2.58	V
Open Loop Voltage Gain	$2\text{V} \leq V_O \leq 4\text{V}$	65	90		dB
Power Supply Rejection Ratio	$12\text{V} \leq V_{DD} \leq 16\text{V}$	60			dB
Output Sink Current	$V_{\text{FB}} = 2.7\text{V}$ , $V_{\text{COMP}} = 1.1\text{V}$	2	14		mA
Output Source Current	$V_{\text{FB}} = 2.3\text{V}$ , $V_{\text{COMP}} = 5\text{V}$	-0.5	-1		mA
High Output Voltage	$V_{\text{FB}} = 2.3\text{V}$ , $R_L = 15\text{ k}\Omega$ to GND	5.0	6.6		V
Low Output Voltage	$V_{\text{FB}} = 2.7\text{V}$ , $R_L = 15\text{ k}\Omega$ to $V_{\text{REF}}$		0.1	1.1	V
Unity Gain Bandwidth	(Note 1)	0.7	1.0		MHz
<b>Current Sense Section</b>					
Gain	Note 2 and 3	2.85	3.0	3.15	V / V
Maximum Threshold	$V_{\text{COMP}} = 5\text{V}$ , (Note 2)	0.9	1.0	1.1	V
PSRR	$12\text{V} \leq V_{DD} \leq 16\text{V}$ , (Note 2)		70		dB
Input Bias Current			-1.0	-2	$\mu\text{A}$
Delay to Output			120	250	ns

#### ◆ ELECTRICAL CHARACTERISTICS

( $T_A = -40^{\circ}\text{C}$  to  $85^{\circ}\text{C}$ , Note 4,  $V_{DD} = 15\text{V}$ ,  $C_T = 3.3\text{ nF}$ ,  $R_T = 11\text{ k}$  , unless otherwise noted )

CHARACTERISTICS	TEST CONDITIONS	MIN	TYP	MAX	UNIT
<b>Output Section</b>					
$R_{DS(ON)}$ High	$I_{SOURCE} = 200\text{mA}$		20		
$R_{DS(ON)}$ Low	$I_{SINK} = 200\text{mA}$		11		
Rise Time	$T_A = 25^{\circ}\text{C}$ , $C_L = 1\text{nF}$		40	80	ns
Fall Time	$T_A = 25^{\circ}\text{C}$ , $C_L = 1\text{nF}$		30	60	ns
<b>Undervoltage Lockout Section</b>					
Start Threshold	GM38C42, GM38C44	13.5	14.5	15.5	V
	GM38C43, GM38C45	7.8	8.4	9.0	
Minimum Operating Voltage	GM38C42, GM38C44	8	9	10	V
	GM38C43, GM38C45	7.0	7.6	8.2	
<b>PWM Section</b>					
Maximum Duty Cycle	GM38C42, GM38C43	94	96		%
	GM38C44, GM38C45	46	50		
Minimum Duty Cycle				0	%
<b>Total Standby Current</b>					
Start - Up Current	$V_{DD} = 13\text{V}$ for GM38C42, GM38C44 $V_{DD} = 7.5\text{V}$ for GM38C43, GM38C45		50	200	$\mu\text{A}$
Operating Supply Current	$V_{FB} = V_{ISNS} = 0\text{V}$		4	6	mA
Zener Voltage ( $V_{DD}$ )	$I_{DD} = 25\text{ mA}$ , Note 6	30	37		V

**Note 1:** These parameters, although guaranteed, are not 100% tested in production.

**Note 2:** Parameter measured at trip point of latch with  $V_{EA} = 0$ .

**Note 3:** Gain defined as:

$$A = \frac{V_{PIN1}}{V_{TH}(I_{SNS})}; 0 \leq V_{TH}(I_{SNS}) \leq 0.8\text{V}$$

**Note 4:** Adjust  $V_{DD}$  above the start threshold before setting at 15V.

**Note 5:** Output frequency equals oscillator frequency for the GM38C42 and GM38C43. Output frequency for the GM38C44, and GM38C45 equals one half the oscillator frequency.

**Note 6:** On 8-pin version, 18V is maximum input on pin 7, as this is also the supply pin for the output stage.

#### ◆ TYPICAL PERFORMANCE CHARACTERISTICS

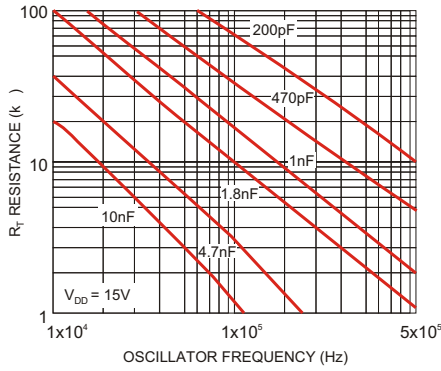

Figure 1. Oscillator Frequency Configuration

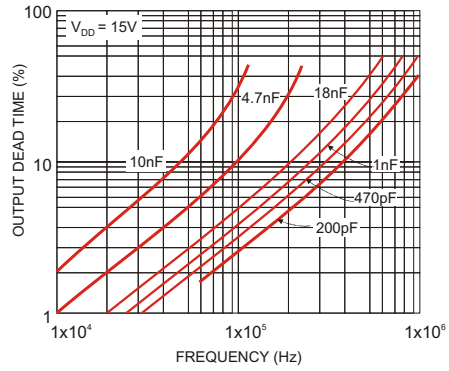

Figure 2. GM38C42, GM38C43 Output Dead Time vs. Oscillator Frequency

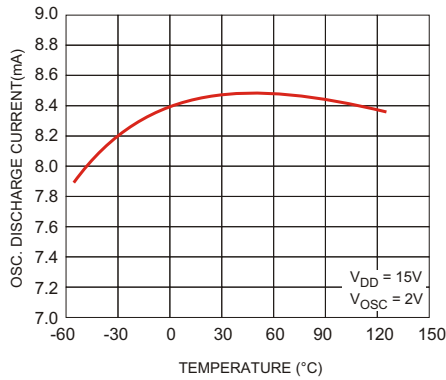

Figure 3. Oscillator Discharge Current vs. Temperature

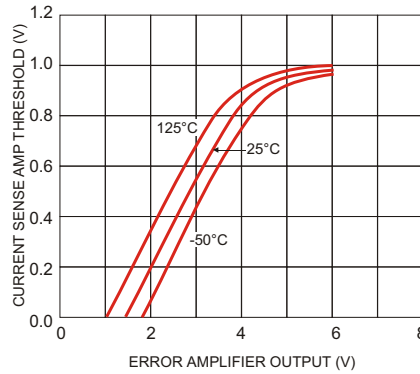

Figure 4. Current Sense Amplifier vs. Error Amplifier Output

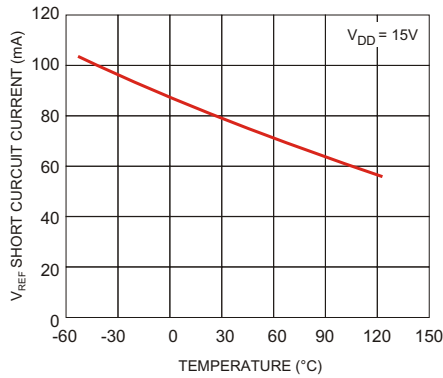

Figure 5. Short - Circuit Reference Current vs. Temperature

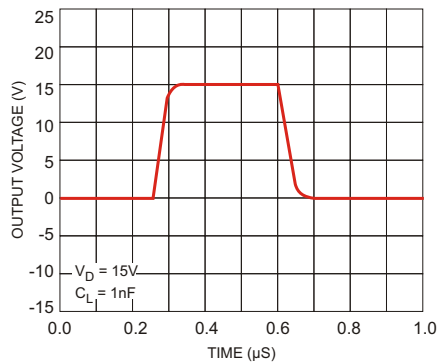

Figure 6. GM38C4X Output Waveform

#### ◆ Application Information

Familiarity with 384x converter designs is assumed.  
GM38C4x has been designed to be compatible with 384xA series controllers.

##### GM38C4x Advantages

###### Start-up Current

Start-up current has been reduced to an ultra-low 50 $\mu$ A(typical) permitting higher-valued, lower-wattage, and start-up resistors (power controller during power supply start-up). The reduced resistor wattage reduces cost and printed circuit space.

###### Operating Current

Operating current has been reduced to 4mA compared to 11mA for a typical bipolar controller. The controller runs cooler and the  $V_{DD}$  hold-up capacitance required during start-up may be reduced.

###### Output Driver

Complementary internal P-and N-channel MOSFETs produce rail-to-rail output voltages for better performance driving external power MOSFETs. The driver transistor's low on resistance and high peak current capability can drive gate capacitances of greater than 100pF. The value of output capacitance which can be driven is determined only by the rise/fall time requirements. Within the restrictions of output capacity and controller power dissipation, maximum switching frequency can approach 500kHz.

###### Design Precautions

When operating near 20V, circuit transients can easily exceed 20V absolute maximum rating and permanently damaging the controller's CMOS construction. To reduce transients, use a 0.1 $\mu$ F low-ESR capacitor to next to the controller's supply  $V_{DD}$  (or  $V_D$  for '-1' versions) and ground connections.

Film type capacitors, such as Wima MKS2, are recommended.

When designing high -frequency converters, avoid capacitive and inductive coupling of the switching waveform into high impedance circuitry such as the error amplifier, oscillator, and current sense amplifier. Avoid long printed-circuit traces and component leads. Locate oscillator and compensation circuitry neat the IC. Use high frequency decoupling capacitors on  $V_{ERF}$ , and if necessary, on  $V_{DD}$ . Return high di/dt currents directly to their source and use large ground planes.

###### Buck Converter

Refer to Figure 7. When at least 26V is applied to the input, C5 is charged through R2 until the voltage  $V_{DD}$  is greater than 14.5V(the undervoltage lockout value of the GM38C42), output switching begins when Q1 is turned on by the gate drive transformer T1 and charging the output filter capacitor C3 through L1. D5 supplies a regulated +12V to  $V_{DD}$  once the circuit is running.

Current sense transformer CT1 provides current feedback to ISNS for current-mode operation and cycle-by-cycle current limiting. This is more efficient than a high- power sense resistor and provides the required ground-referenced level shift.

When Q1 turns off, current flow continues from ground through D1 and L1 until Q1 is turned on again.

The 100V Schottky diode D1 reduces the forward voltage drop in the main current path, resulting in higher efficiency than could be accomplished by using an ultra-fast recovery diode. R1 and C2 suppress parasitic oscillations from D1.

Using a high-value inductance for L1 and a low-ESR capacitor for C3 permits small capacitance with minimum output ripple. This inductance value also improves circuit efficiency by reducing the flux swing in L1. Magnetic components are carefully chosen for minimal loss at 500kHz.

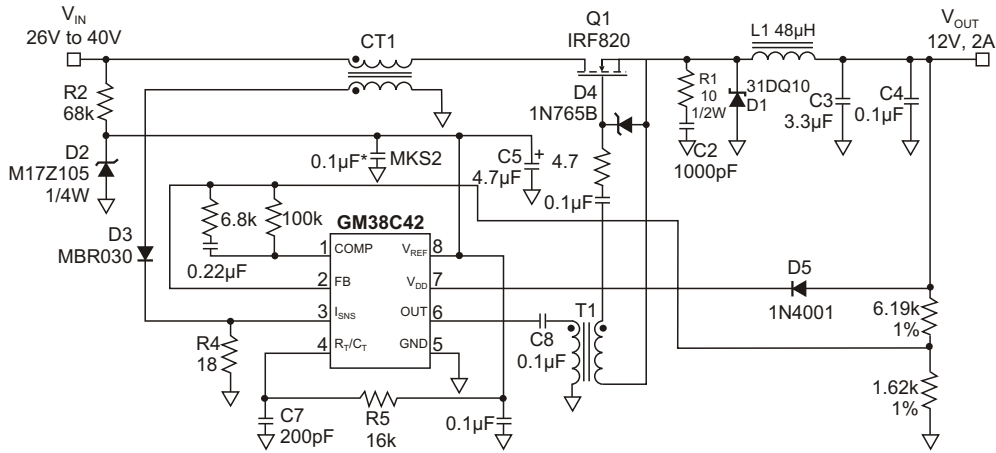

\* Locate near GM38C42 supply pins

Figure 7. 500kHz, 25W, Buck Converter

Test	Conditions	Results
Line Regulation	$V_{IN} = 26V$ to $80V$ , $I_O = 2A$	0.5%
Load Regulation	$V_{IN} = 48V$ , $I_O = 0.2A$ to $2A$	0.6%
Efficiency	$V_{IN} = 48V$ , $I_O = 2A$	90%
Output Ripple	$V_{IN} = 48V$ , $I_O = 2A$ (20MHz BW)	100mV



#### ◆ SOP-8 PACKAGE OUTLINE DIMENSIONS

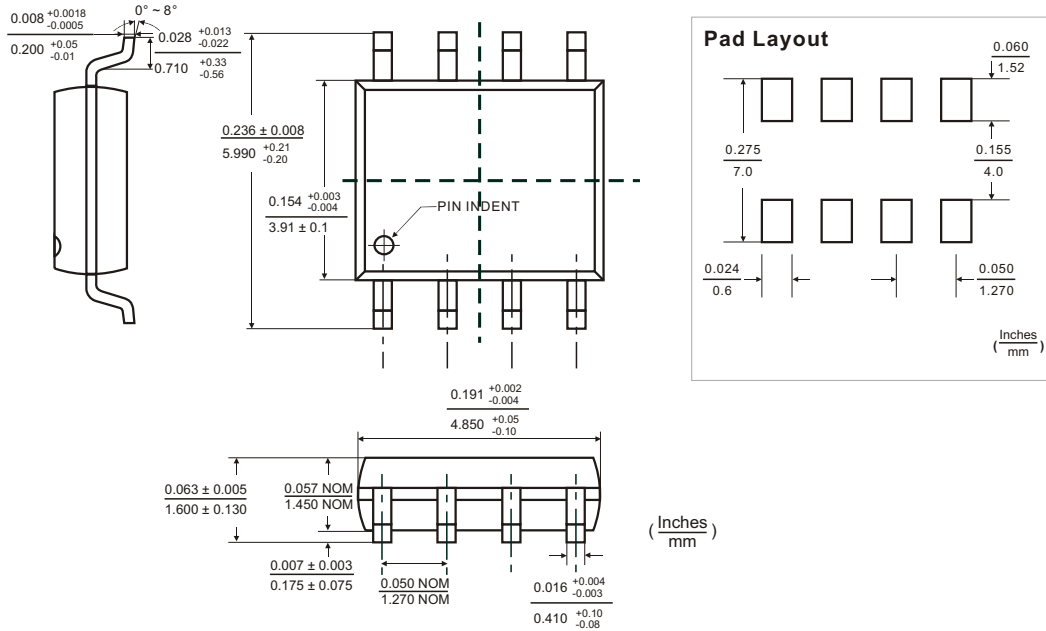

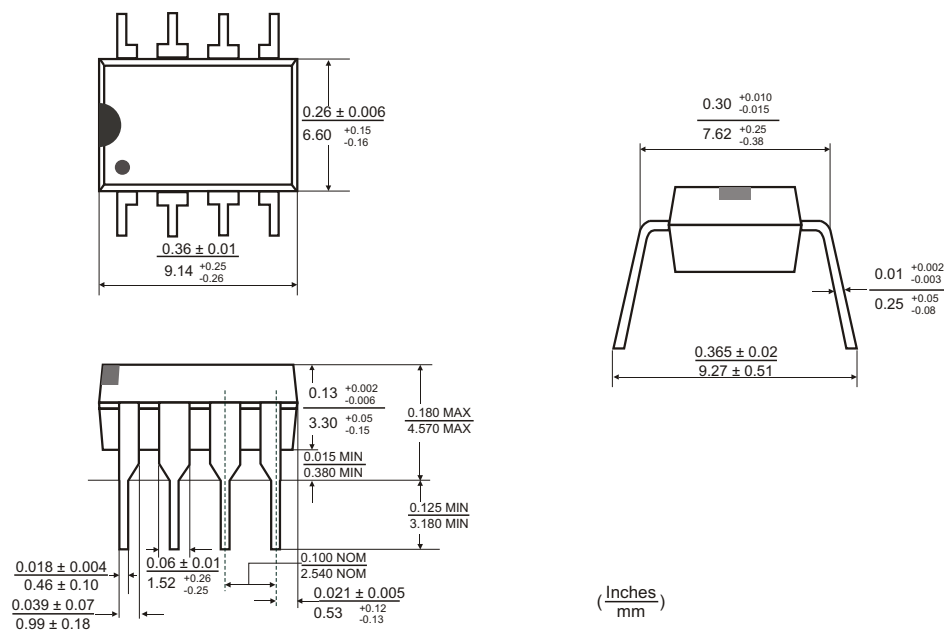

#### ◆ DIP-8 PACKAGE OUTLINE DIMENSIONS

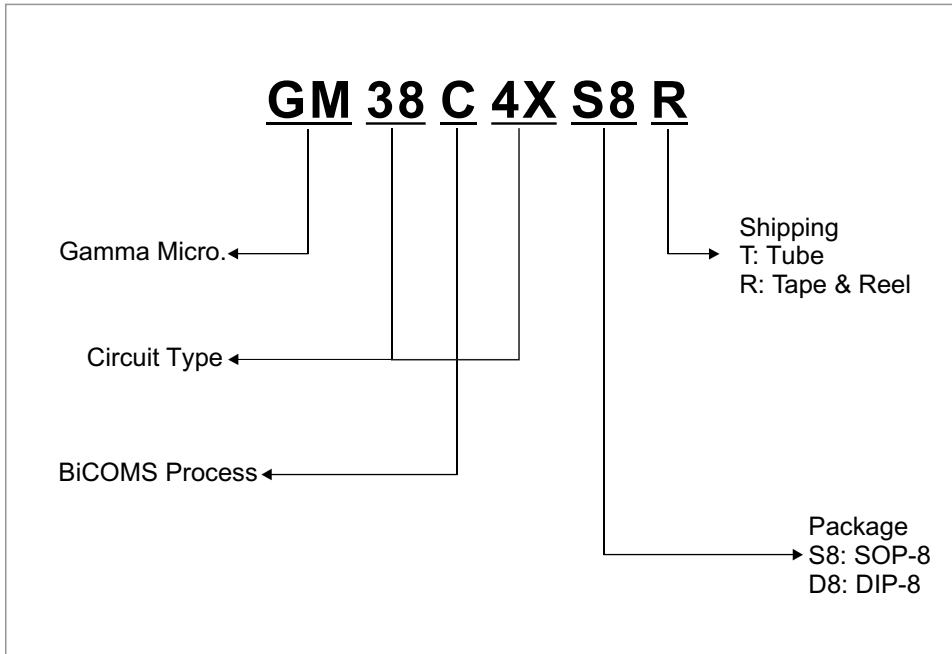

#### ◆ ORDERING NUMBER



---

GAMMA Micro, , and  are registered trademarks of GAMMA MICROELECTRONICS INC. GAMMA reserves the right to make changes without further notice to any products herein. Information provided herein is alleged to be exact and consistent and this publication surpasses and replaces all information previously supplied.

GAMMA makes no warranty the suitability of its products for any particular purpose, nor does GAMMA assume any liability arising out of the application or use of any product or circuit, and specifically disclaims any and all liability including without limitation special, consequential or incidental damages.

GAMMA products are not authorized for using as critical components in life support devices or systems without prior written approval from GAMMA MICROELECTRONICS INC.

---