

Description

GM6350 is a group of positive voltage output, three - pin regulators, that provide a high current even when the input/output voltage differential is small. Low power consumption and high accuracy is achieved through CMOS and programmable fuse technologies. Output voltage: 1.5V to 5.0V.

GM6350 consists a high-precision voltage reference, an error correction circuit, and a current limited output driver. Transient response to load variations have improved in comparison to the existing series.

GM6350 incorporates both over-temperature and over-current protection.

Features

- ◆ **Maximum output current: 300mA**
- ◆ **Highly accurate: Output voltage $\pm 2\%$**
- ◆ **Low power consumption.**
- ◆ **Over -Current and Over-Temperature protection**
- ◆ **Small input/ output differential: 0.3V at 300mA**

Application

Battery- Operated Systems

Portable Computers

Portable Cameras and Video Recorders

Reference voltage Sources

Instrumentation

Pagers

TYPICAL APPLICATION

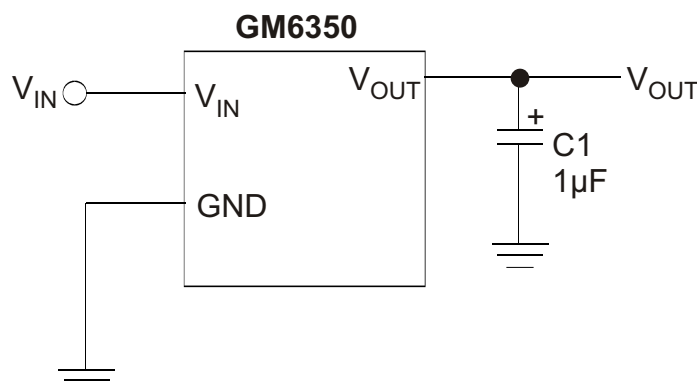

◆ MARKING INFORMATION & PIN CONFIGURATIONS (TOP VIEW)

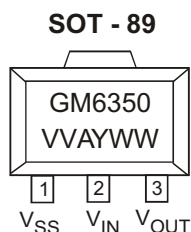

VV = Voltage Code
 A = Assembly Location
 Y = Year
 WW = Weekly

◆ ORDERING INFORMATION

Ordering Number	Output Voltage	Package	Shipping
GM6350-1.5ST89R	1.5	SOT-89	1,000 Units/ Tape & Reel
GM6350-1.8ST89R	1.8	SOT-89	1,000 Units/ Tape & Reel
GM6350-2.5ST89R	2.5	SOT-89	1,000 Units/ Tape & Reel
GM6350-3.0ST89R	3.0	SOT-89	1,000 Units/ Tape & Reel
GM6350-3.3ST89R	3.3	SOT-89	1,000 Units/ Tape & Reel
GM6350-5.0ST89R	5.0	SOT-89	1,000 Units/ Tape & Reel

* For detail Ordering Number identification, please see last page.

◆ PIN DESCRIPTION

Pin Name	Pin Name	Function
SOT-25		
1	V_{SS}	Unregulated Supply Input.
2	V_{IN}	Ground Terminal.
3	V_{OUT}	Regulated Voltage Output.

◆ ABSOLUTE MAXIMUM RATINGS

PARAMETER	SYMBOL	RATINGS	UNITS
Input Voltage	V_{IN}	6.5	V
Output Current	I_{OUT}	300	mA
Output Voltage	V_{OUT}	$V_{SS} - 0.3 \sim V_{IN} + 0.3$	V
Continuous Total Power Dissipation	SOT-89 P_D	500	mW
Operating Ambient Temperature	T_{OPR}	-30 ~ +80	°C
Storage Temperature	T_{STG}	-40 ~ +125	°C

◆ ELECTRICAL CHARACTERISTICS

($T_A = 25^\circ\text{C}$, $V_{IN} = V_{OUT}$ (nominal) + 0.5V, unless otherwise noted)

Parameter	Test Condition	Min	Typ	Max	Units	Test Circuit
Output Voltage Accuracy	$I_O = 1\text{mA}$, $I_O = 0.1 \dots 300\text{mA}$	-1.4 -3%		+1.4% +2%	V	
Line Regulation $V_{OUT} / V_{IN} V_{OUT}$	$I_O = 1\text{mA}$, $(V_{OUT} + 0.1\text{V}) < V_{IN} < 6.5\text{V}$		0.1	0.3	%/V	1
Load Regulation (Note 1)	$V_{IN} = 6\text{V}$, $0.1\text{mA} < I_O < 300\text{mA}$, $C_{OUT} = 1\mu\text{F}$		0.005	0.04	%/mA	2
Maximum Output Current	$V_{IN} = 5\text{V}$, $V_{OUT} > 0.96 \cdot V_{rating}$	300	500		mA	
Current Limit		400			mA	
Ground Pin Current	$I_{OUT} = 0 \dots 300\text{mA}$		15	30	μA	3
Dropout Voltage for $V_{OUT} > 2.5\text{V}$	$I_O = 100\text{mA}$		100	180	mV	
	$I_O = 300\text{mA}$		300	550		
for $2.0\text{V} < V_{OUT} \leq 2.5\text{V}$	$I_O = 100\text{mA}$		150	300		
	$I_O = 300\text{mA}$		450	800		
for $V_{OUT} \leq 2.5\text{V}$	$I_O = 100\text{mA}$		200	400		
	$I_O = 300\text{mA}$		600	1100		

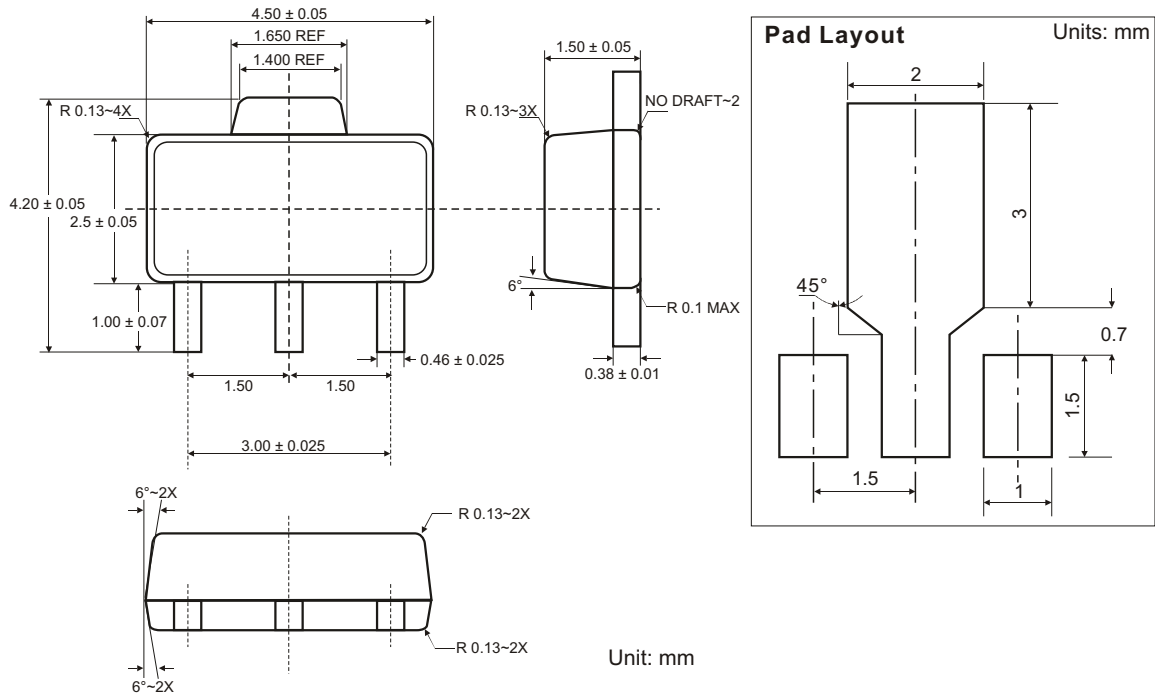

Note 1: Load Regulation is measured using pulse techniques with duty cycle <5%

◆ SOT-89 PACKAGE OUTLINE DIMENSIONS

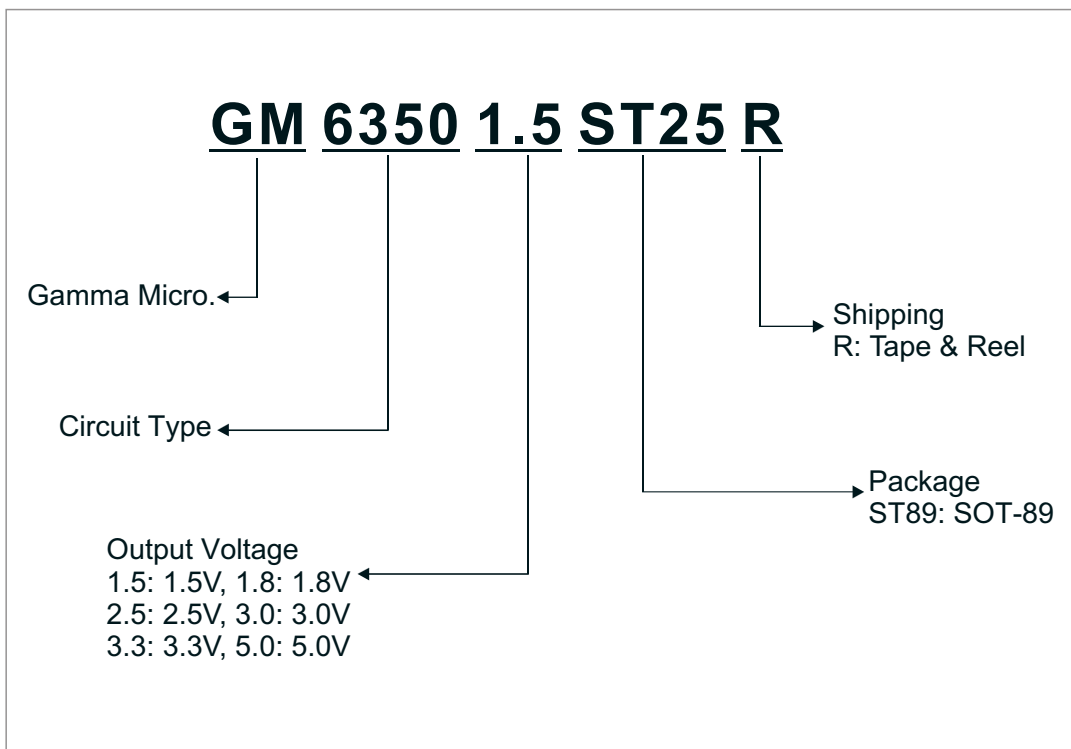

◆ ORDERING NUMBER



GAMMA Micro, , and  are registered trademarks of GAMMA MICROELECTRONICS INC. GAMMA reserves the right to make changes without further notice to any products herein. Information provided herein is alleged to be exact and consistent and this publication surpasses and replaces all information previously supplied.

GAMMA makes no warranty the suitability of its products for any particular purpose, nor does GAMMA assume any liability arising out of the application or use of any product or circuit, and specifically disclaims any and all liability including without limitation special, consequential or incidental damages.

GAMMA products are not authorized for using as critical components in life support devices or systems without prior written approval from GAMMA MICROELECTRONICS INC.
